

Diaphragm Seal

990.27 with flange and flush diaphragm
with pressure transmitter

E 06.02.04

Ed.17.01

Design	Diaphragm Seal with flush diaphragm and flange acc.to EN 1092-1 or ASME B 16,5 Pressure transmitter in stainless steel
Type	990.27
Lower body	Flush diaphragm with flange connection acc.to EN 1092-1 or ASME B 16,5
Flange EN 1092-1	DN 25, DN 40, DN 50, DN 80, DN 100 or DN 125 Sealing face form B1 (B2 in special materials) Pressure rate PN 10 to PN 250
Flange ASME B 16,5	DN 1", 1½", 2", 3", 4" or 5" Sealing face RF 125...250 AA Option RFSF, RJF-groove, small tongue, large tongue Pressure rate 150, 300, 600, 900, 1500 or 2500 lbs
Material standard	Body of stainless steel 1.4404 (316L) Wetted parts of stainless steel 1.4435 (316L) Special materials see page 2
Level of cleanliness	Oil and grease free per ASTM G93-03 level E (< 550 mg/m2)
Working Pressure	90% of full scale range by fluctuating pressure full scale value by short time pressure
Process temperature	Process temperature standard max +150°C Option lowest temperature to max -90°C Option highest temperature to max +400°C Max temperature depending on material and filling media
Ambient temperature	Ambient temperature standard +10+40°C Option lowest temperature to max -40°C Option highest temperature to max +60°C
Cooling/capillary	The pressure instrument must be protected in process temperatures over +200°C with cooling tower or capillary
Filling media	KN 2 silicone oil (standard) temperature -45+300°C KN 17 silicone oil for low temperatures -90+200°C KN 32 silicone oil for high temperatures -25+400°C KN 21 halocarbene for oxygen and chlorine -60+175°C KN 70 silicone free filling -20+200°C KN 59 Neobee M-20 FDA (Food & Pharma) -35+260°C KN 92 white mineral oil FDA (Food & Pharma) -15+260°C
Certificate (option)	EN 10204-3.1 Certificate wetted parts incl. chemical analysis EN 10204-3.1 Certification of class and accuracy EN 10204-3.1 Accuracy calibration values listed EN 10204-3.1 Pressure and stability test EN 10204-3.1 Helium leak test
More options	Mounted TAG-schild with customer numbers Design according to NACE MR 0175 or MR 0103 Origen of wetted parts from EU, Schweiz or USA Flange acc.to Gost 33259, API 6A or JIS B 2220



990.27 DN 25
flange EN 1092-1
pressure transmitter
S-20

Diaphragm Seal

990.27 with flange and flush diaphragm
with pressure transmitter

E 06.02.04

Material for body and wetted parts

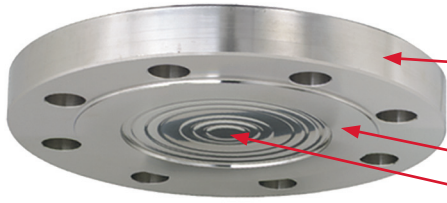

Flange body

Standard = stainless steel 1.4404 (316L)

Wetted parts

Wetted parts are diaphragm and sealing face

Standard = stainless steel 1.4435 (316L)

Body stainless steel 1.4404 (316L) Wetted parts	Temperature
Stainless steel 1.4435 (316 L) standard	max +400°C
Stainless steel 1.4541 (321)	max +400°C
Stainless steel 1.4571 (316Ti)	max +400°C
Stainless steel with ECFTE-coating	max +150°C
Stainless steel with PFA-coating	max +260°C
Stainless steel with Gold-plating	max +400°C
Hastelloy C22 (2.4602)	max +260°C
Hastelloy C276 (2.4819)	max +400°C

Body stainless steel 1.4404 (316L) Wetted parts	Temperature
Inconel 600 (2.4816)	max +400°C
Inconel 625 (2.4856)	max +400°C
Incoloy 825 (2.4858)	max +400°C
Monel 400 (2.4360)	max +400°C
Nickel	max +260°C
Titanium (3.7035)	max +150°C
Titanium (3.7235)	max +150°C
Tantalum	max +150°C

Flange + wetted parts	Temperature
Syrafast stål 1.4571 (316Ti)	max +400°C
Duplex 2205 (1.4462)	max +300°C
Superduplex 2507 (1.4410)	max +300°C
Hastelloy C22 (2.4602)	max +260°C
Hastelloy C276 (2.4819)	max +400°C

Flange + wetted parts	Temperature
Incoloy 825 (2.4858)	max +400°C
Monel 400 (2.4360)	max +400°C
Nickel	max +400°C
Titanium (3.7035)	max +400°C
Titanium (3.7235)	max +260°C

Diaphragm Seal

990.27 with flange and flush diaphragm
with pressure transmitter

E 06.02.04

Pressure transmitters for mounting with diaphragm seal 990.27



Pressure transmitter S-20

Standard design
Non-linearity 0,25% BFSL
Case in stainless steel 316L
Wetted parts in stainless steel 316L
Output signal 4-20 mA or 0-10 V
Connector DIN EN 175301-803 A,
Circular connector M12x1 or cable outlet IP67 or IP68



Pressure transmitter IS-3

Ex ATEX design
Non-linearity 0,25% BFSL
Case in stainless steel 316L
Wetted parts in stainless steel 316L
Output signal 4-20 mA or 0-10 V
Connector DIN EN 175301-803 A,
Circular connector M12x1 or cable outlet IP67 or IP68
Ex ATEX and IECEx II 1/2 G Ex ia IIC T4/T6 Ga/Gb + 1 M1 Ex ia I Ma



Pressure transmitter F-20

with field case
Non-linearity 0,25% BFSL
Case in stainless steel 316L
Wetted parts in stainless steel 316L
Output signal 4-20 mA or 0-10 V
Field case in stainless steel
Ingress protection IP 67



Pressure transmitter PGT23.100

With analogue on-site display, case 100 mm
Safety version with safety wall behind the scale
Non-linearity 0,5% BFSL
Case in stainless steel 316L
Wetted parts in stainless steel 316L
Output signal 4-20 mA or 0-10 V
Option with liquid filled case

Diaphragm Seal

990.27 with flange and flush diaphragm
with pressure transmitter

E 06.02.04

Pressure transmitter S-20 with diaphragm seal 990.27 DN 25 EN 1092-1 PN 10/40

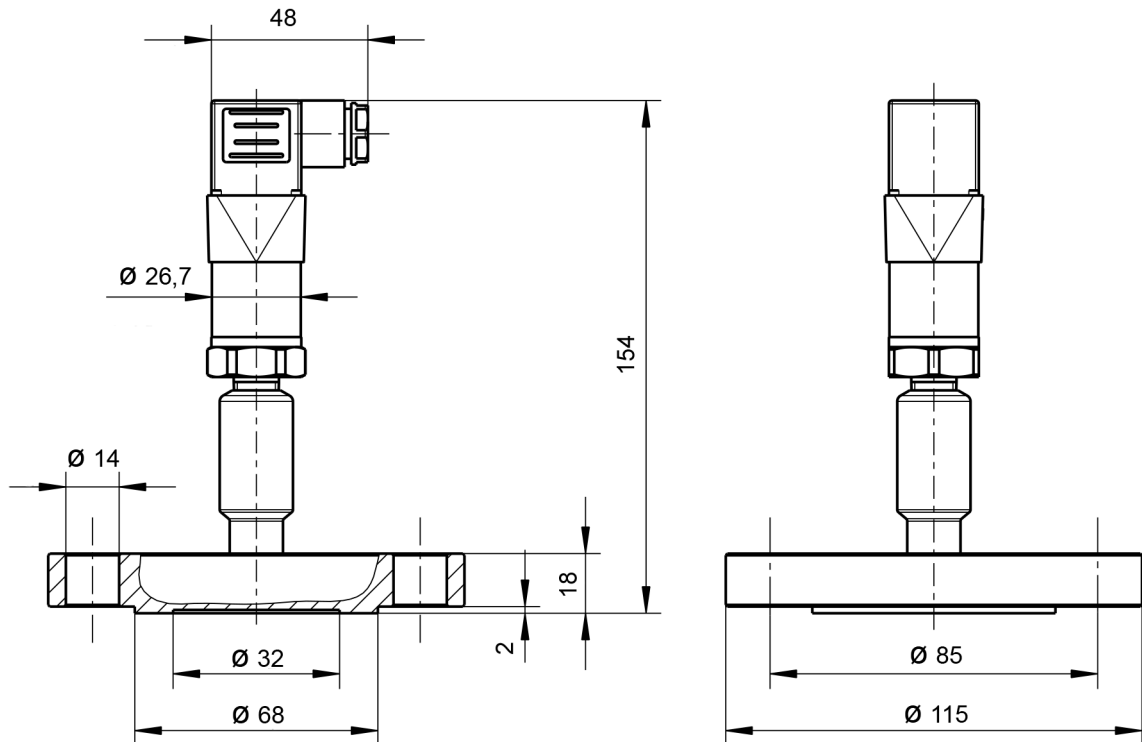

Pressure transmitter S-20 with diaphragm seal 990.27 DN 50 EN 1092-1 PN 10/40

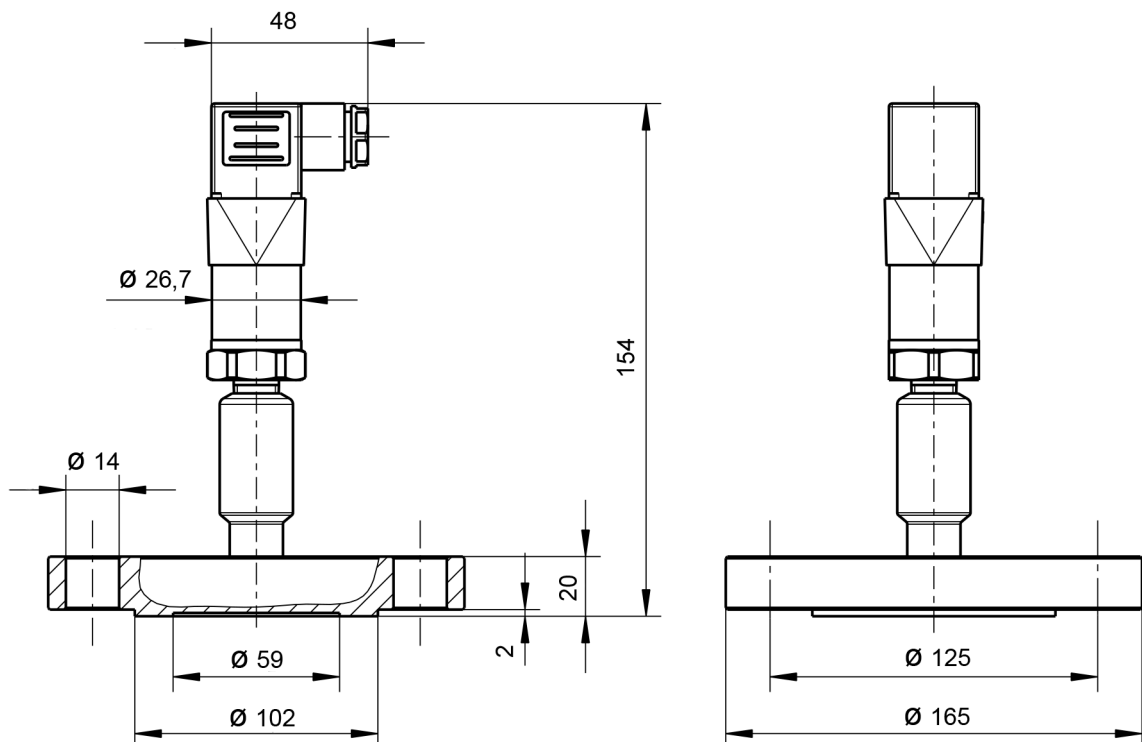

Diaphragm Seal

990.27 with flange and flush diaphragm
with pressure transmitter

E 06.02.04

Flange EN 1092-1, form B1 - DIN 2501, form D
Size DN 25, 40, 50, 80, 100 or 125

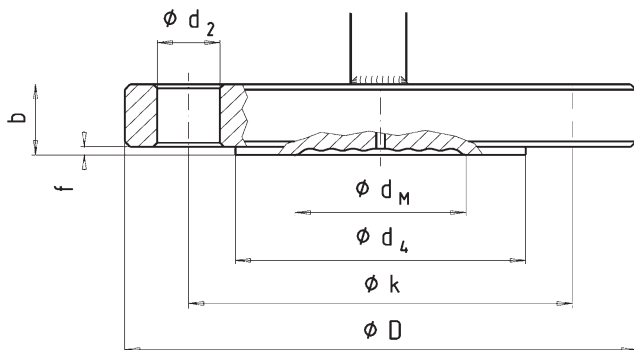

x = mounting holes

DN	PN	Dimension mm					Sealing face			Weight kg
		dm	D	b	d ₂	k	f	d ₄	x	
25	10/40	32	115	18	14	85	2	68	4	1.5
	63/100	25	140	24	18	100	2	68	4	2.5
40	10/40	45	150	18	18	110	2	88	4	2.1
	63/100	45	170	26	22	125	2	88	4	4.0
	160	45	170	28	22	125	2	88	4	4.3
50	250	45	185	34	26	135	2	88	4	6.3
	10/40	59	165	20	18	125	2	102	4	3.3
	63	59	180	26	22	135	2	102	4	5.1
	100	59	195	28	26	145	2	102	4	6.5
80	160	59	195	30	26	145	2	102	4	7.0
	250	59	200	38	26	150	2	102	8	9.3
	10/16	89	200	20	18	160	2	138	8	4.9
	25/40	89	200	24	18	160	2	138	8	5.8
	63	89	215	28	22	170	2	138	8	7.9
100	100	89	230	32	26	180	2	138	8	10.4
	160	89	230	36	26	180	2	138	8	11.7
	250	89	255	46	30	200	2	138	8	18.4
	10/16	89	220	20	18	180	2	158	8	5.9
125	25/40	89	235	24	22	190	2	162	8	8.1
	63	89	250	30	26	200	2	162	8	11.5
	100	89	265	36	30	210	2	162	8	15.5
	160	89	265	40	30	210	2	162	8	17.3
	250	89	300	54	33	235	2	162	8	29.9
125	10/16	124	250	22	18	210	2	188	8	8.4
	25/40	124	270	26	26	220	2	188	8	11.6
	63	124	295	34	30	240	2	188	8	14.7
	100	124	315	40	33	250	2	188	8	24.4
	160	124	315	44	33	250	2	188	8	26.9
250	124	340	60	33	275	2	188	12	42.7	

Diaphragm Seal

990.27 with flange and flush diaphragm
with pressure transmitter

E 06.02.04

Flange ASME 16,5, RF 125...250 AA
Size DN 1", 1 1/2", 2", 3" or 4"

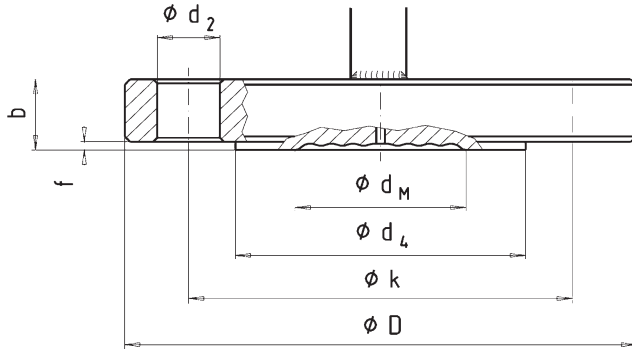

x = mounting holes

DN	Class	Dimension mm			Sealing face					Weight kg
		dm	D	b	d ₂	k	f	d ₄	x	
1"	150	32	110	14.7	16	79.4	2	51	4	1.4
	300	32	125	17.9	19	88.9	2	51	4	1.7
1 1/2"	150	45	125	17.9	16	98.4	2	73	4	1.6
	300	45	155	21.1	22	114.3	2	73	4	2.5
	600	45	155	29.3	22	114.3	7	73	4	3.3
	1500	45	180	38.8	29	123.8	7	73	4	5.9
	2500	45	205	51.5	32	146	7	73	4	10.4
2"	150	59	150	19.5	19	120.7	2	92	4	2.7
	300	59	165	22.7	19	127	2	92	8	3.7
	600	59	165	32.4	19	127	7	92	8	5.7
	1500	59	215	45.1	26	165.1	7	92	8	13.2
	2500	59	235	57.9	29	171.4	7	92	8	19.8
3"	150	89	190	24.3	19	152.4	2	127	4	5.3
	300	89	210	29	22	168.3	2	127	8	7.8
	600	89	210	38.8	22	168.3	7	127	8	11
	900	89	240	45.1	26	190.5	7	127	8	16.7
	1500	89	265	54.7	32	203.2	7	127	8	24.5
	2500	89	305	73.7	35	228.6	7	127	8	42.7
4"	150	89	230	24.3	19	190.5	2	158	8	7.7
	300	89	255	32.2	22	200	2	158	8	12.7
	400	89	255	42	26	200	7	158	8	17.4
	600	89	275	45.1	26	215.9	7	158	8	21.5
	900	89	290	51.5	32	235	7	158	8	27.7
	1500	89	310	61	35	241.3	7	158	8	37
	2500	89	355	83.2	42	273	7	158	8	65.7